

**ASSEMBLY OF THE US-JAPAN JP-27 EXPERIMENT AND START OF IRRADIATION IN THE HFIR—**  
D. K. Felde, K. R. Thoms, D. W. Heatherly, S. H. Kim, R. G. Sitterson, and R. E. Stoller (Oak Ridge National Laboratory) and H. Tanigawa (Japan Atomic Energy Research Institute, Tokai, Japan)

## **OBJECTIVE**

This work is being carried out under Annex I of the Collaboration on Fusion Materials between the U.S. DOE and the Japan Atomic Energy Research Institute. The JP-27 experiment is one component of the Phase-IV experiments with the goal of elucidating the effects of helium in candidate engineering and model alloys and verifying the irradiation response of alloy F82H.

## **SUMMARY**

Specimen and capsule parts fabrication for JP-27 was completed. Loading of specimens into specimen holders and assembly of the capsule was completed. The experiment was installed in the target region of HFIR and irradiation began with cycle 400, starting April 27, 2004.

## **PROGRESS AND STATUS**

### **Introduction**

This experiment is being carried out within the framework of the US DOE-JAERI Collaboration on Fusion Materials, Annex I, which is in its fourth phase. The goals of the experiment include the investigation of the effects of helium on microstructural evolution, the impact of helium on fracture properties, and the development of engineering data on the fusion candidate alloy F82H. The goal of this report is to provide a detailed description of the final design of the JP-27 capsule and a detailed list of specimens loaded into JP-27.

### **Description of JP-27 Capsule**

The JP-27 capsule includes 16 specimen holders designed to accommodate 6 types of specimens and irradiate them at 3 temperatures, 300, 400, and 500°C. The specimen types are a small bend bar (deformation-fracture mini-beam, DFMB), a sheet tensile specimen (SS-J3), a subsized pre-cracked Charpy V-notch specimen (M3-PCCVN), transmission electron microscopy disks (TEM), atom probe specimens (APFIM), and small multi-purpose coupons (MMPC) that have the same overall dimensions as the APFIM specimens.

An overall layout of the JP-27 experiment is shown in Table 1, which provides the subcapsule position number, the specimen type being irradiated in that position, the design irradiation temperature, and the distance that the center of the subcapsule is from the HFIR horizontal mid-plane (HMP).

Each of the specimen holders is fabricated from oxide dispersion strengthened aluminum (DISPAL). The outside diameters of the specimen holders are sized to provide a precise helium-filled gas gap between the holder and the capsule housing tube necessary to achieve the desired irradiation temperature. Centering tabs, six at each end, are machined into the holders to help assure uniform gas gaps. The inner part of the specimen holder is machined to accommodate the type of specimens being irradiated, and therefore each has a unique geometry. Silicon carbide (SiC) passive temperature monitors are included in each specimen holder. These will be analyzed after irradiation to determine actual irradiation temperature.

**Table 1. Layout of the JP-27 experiment**

<b>Position number</b>	<b>Specimen type</b>	<b>Design temp. (°C)</b>	<b>Distance above HMP* (in.)</b>
1	TEM	400	9.487
2	M3-PCCVN	300	8.357
3	M3-PCCVN	300	6.783
4	SS-J3	300	5.287
5	SS-J3	400	3.869
6	SS-J3	400	2.451
7	M3-PCCVN	400	0.955
8	TEM	500	-0.175
9	DFMB	500	-0.958
10	DFMB	400	-1.838
11	M3-PCCVN	400	-3.065
12	DFMB	300	-4.292
13	M3-PCCVN	300	-5.519
14	SS-J3	300	-7.015
15	SS-J3	300	-8.433
16	TEM	300	-9.485

\* HMP – Horizontal Mid-plane.

A top view and axial cross section of the specimen holders used to irradiate TEM specimens (positions 1, 8, and 16) is shown in Fig. 1 (all dimensions in Figs. 1 through 4 are in inches unless otherwise noted). A total of 100 (0.010 in. thick) specimens can be accommodated in these holders, along with a single SiC temperature monitor located at the center of the holder. To help identify in which hole the specimens are located, a 0.040-in. diameter by 0.040-in. deep hole was drilled in the top of each TEM holder, and the specimen holes are then numbered clockwise starting at this 0.040-in. hole.

The loading configuration for the tensile specimen holders is shown in Fig. 2. Eight SS-J3 tensile and eight APFIM specimens can be accommodated per layer, with two layers per holder. Six holders are located at positions 4, 5, 6, 14, and 15, each with a total of 16 tensile and APFIM specimens. A spring pin is placed in the center of the specimen array to apply pressure to the SiC temperature monitors and, in turn, on the tensile specimens to assure good thermal contact with the specimen holder. At each corner two APFIM “tuning fork” specimens are loaded with a corrugated spring to assure that they are also in good thermal contact with the holder. In some of the tensile specimen holders, two multi-purpose coupons (MMPC) and spacers that combined have the same overall dimensions as the APFIM specimens were substituted for the APFIM specimens (see loading list).

Subsized pre-cracked Charpy V-notch specimens (M3-PCCVN) are loaded into specimen holders shown in Fig. 3. Each of these holders (positions 2, 3, 7, 11, and 13) has a total of 8 specimens. Two SiC temperature monitors and corrugated springs are placed in the center of the specimen array to assure good thermal contact with the holder.

The DFMB specimens are loaded into three holders (positions 9, 10, and 12) as shown in Fig. 4. There are two layers of specimens with 16 specimens at each level. The outer row of each layer is made up of 12 specimens that are 1.68 mm square, while the inner four specimens are either 0.40 x 3.3 mm or 0.890 x 3.3 mm. A SiC temperature monitor and a corrugated spring are placed in the center of the specimen array, and two corrugated springs are placed in two of the outer rows to assure all specimens are in good thermal contact with the holder. Specimen locations are designated by a C, S, TM, M1 or M2, to more precisely identify loading locations (see loading list).

## Specimen Loading

The location of each of the nearly 600 specimens in JP-27 is reported in Table 2, which contains a box for each of the 16 specimen holders and 5 dosimeter positions. Because coatings applied to some of the TEM discs required the discs to be loaded in a prescribed manner, the boxes for the TEM specimen holders (positions 1, 8, and 16) have a column labeled "Engr. Face" to indicate which way the engraved face of the specimen was loaded. A total of five neutron dosimeter packages provided by PNNL were loaded into JP-27, one each between positions 1 and 2, 3 and 4, 7 and 8, 12 and 13, and below position 16. The M3-PCCVN specimens (in positions 2, 3, 7, 11, and 13) were all loaded with the notches facing towards the center of the holders. The outer rows of specimens in the DFMB holders (positions 9, 10, and 12) were loaded with the notches facing outward toward the holder, while the inner four specimens were loaded with their notches facing inward toward the center of the holder.

## FUTURE WORK

The JP-27 capsule will be irradiated to a peak fluence of 25 dpa, which will take approximately 13 HFIR cycles.

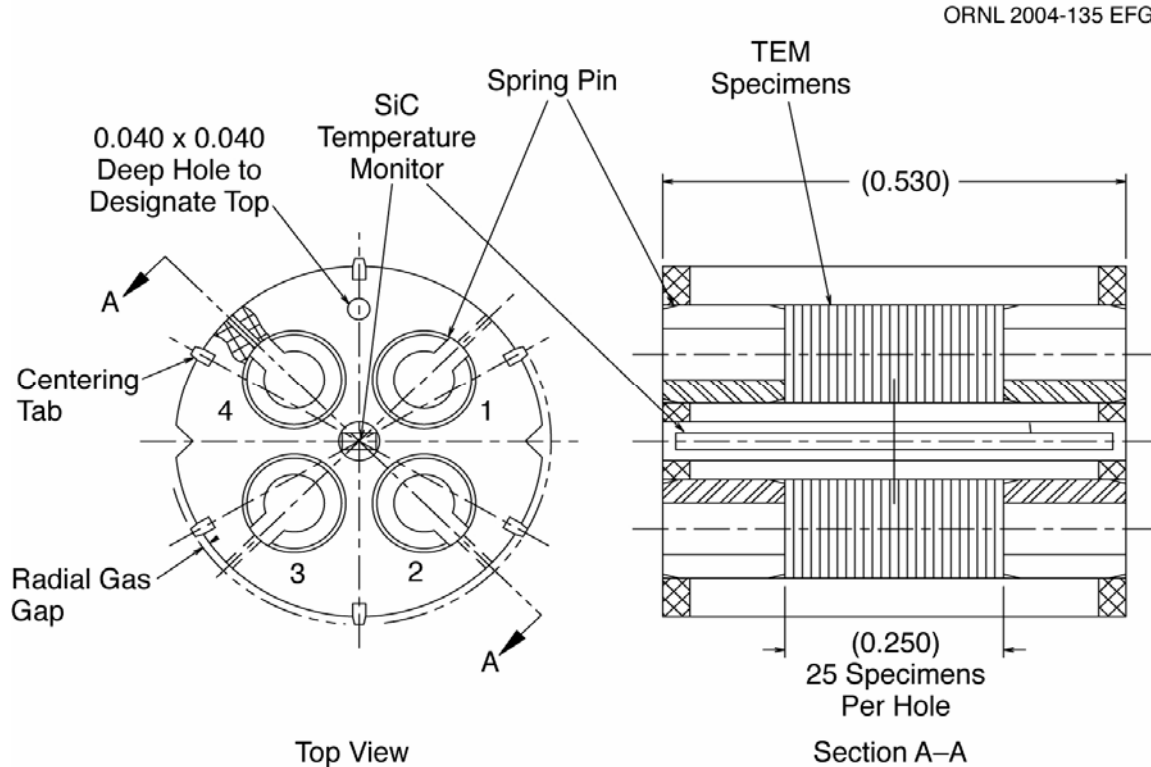

Fig. 1. Specimen holder subassembly used in JP-27 for TEM specimens.

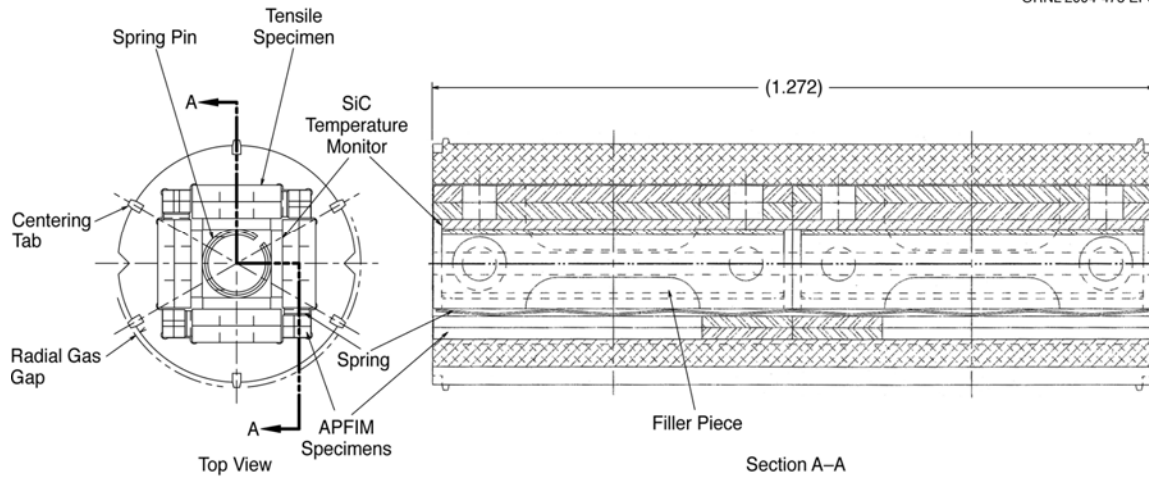

Fig. 2. Specimen holder subassembly used in JP-27 for SS-J3 tensile and APFIM specimens.

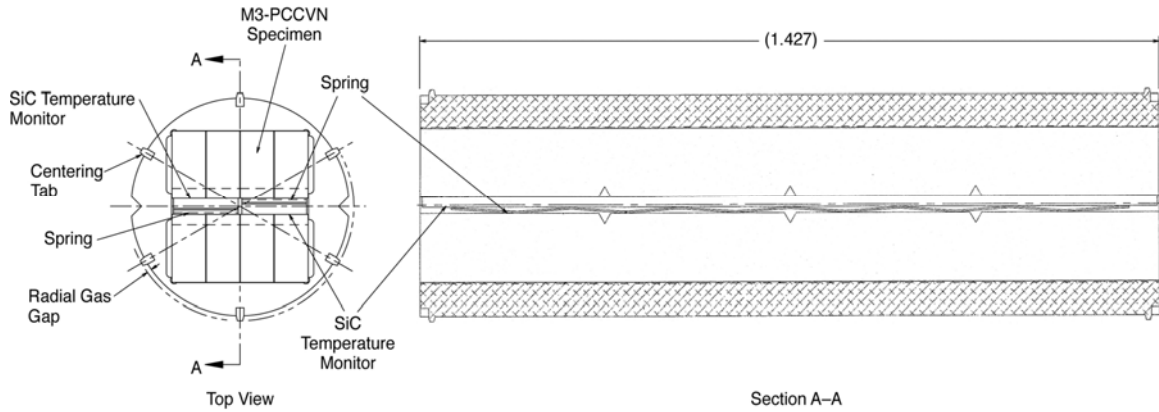

Fig. 3. Specimen holder subassembly used in JP-27 for M3-PCCVN specimens.

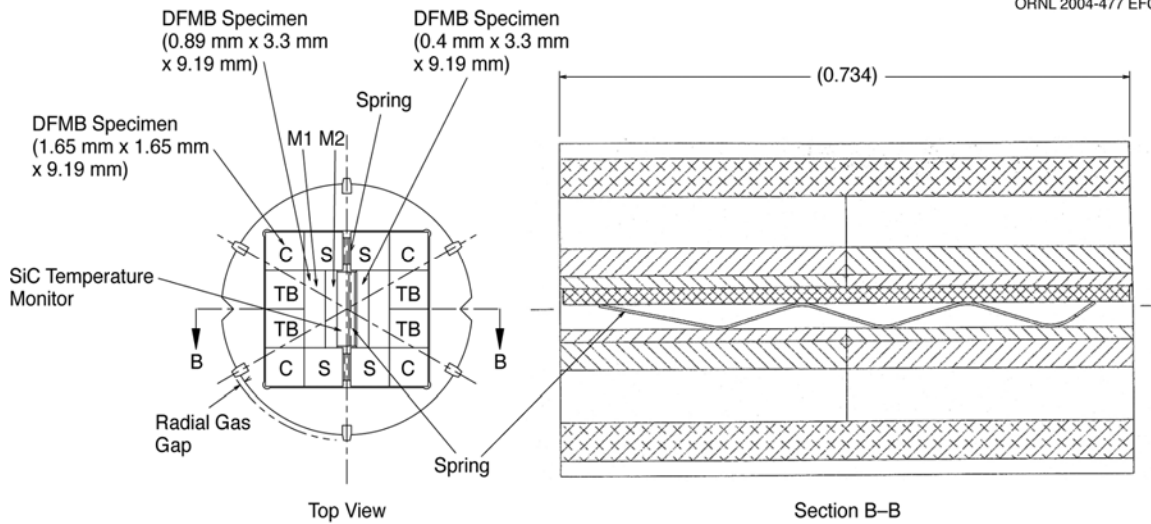

Fig. 4. Specimen holder subassembly used in JP-27 for DFMB specimens.

Table 2. JP-27 specimen and dosimetry loading list

POS. 1 JP-27	TEM specimen numbers									Passive thermometry in center hole
		Hole No.1*	Engr. face	Hole No.2*	Engr. face	Hole No.3*	Engr. face	Hole No.4*	Engr. face	
BOTTOM	1	<b>046</b>	Down	<b>ZQ43</b>	Down	<b>042</b>	Down	<b>H41</b>	Up	Ser. # 1
	2	<b>ZA45</b>	Up	<b>ZK43</b>	Up	<b>ZA42</b>	Up	<b>UN40</b>	Up	
	3	<b>057</b>	Down	<b>ZH43</b>	Down	<b>043</b>	Down	<b>UN41</b>	Up	
	4	<b>ZF46</b>	Up	<b>ZK44</b>	Up	<b>ZF42</b>	Up	<b>340</b>	Up	
	5	<b>H46</b>	Down	<b>ZR46</b>	Down	<b>H42</b>	Down	<b>341</b>	Up	
	6	<b>ZF47</b>	Up	<b>ZN42</b>	Up	<b>ZF43</b>	Up	<b>R40</b>	Up	
	7	<b>H47</b>	Down	<b>ZR45</b>	Down	<b>H43</b>	Down	<b>R41</b>	Up	
	8	<b>UN46</b>	Up	<b>ZN43</b>	Up	<b>UN42</b>	Up	<b>ZG40</b>	Up	
	9	<b>R46</b>	Down	<b>044</b>	Down	<b>R42</b>	Down	<b>ZG41</b>	Up	
	10	<b>UN47</b>	Up	<b>ZA43</b>	Up	<b>UN43</b>	Up	<b>ZH40</b>	Up	
	11	<b>R47</b>	Down	<b>H44</b>	Down	<b>R43</b>	Down	<b>ZH41</b>	Up	
	12	<b>ZH44=</b>	Up	<b>ZA44</b>	Up	<b>ZP42</b>	Up	<b>ZJ40</b>	Up	
	13	<b>ZG42</b>	Down	<b>H45</b>	Down	<b>H58</b>	Up	<b>ZJ41</b>	Up	
	14	<b>ZP43</b>	Up	<b>ZF44</b>	Up	<b>ZB41</b>	Up	<b>ZK40</b>	Up	
	15	<b>ZG43</b>	Down	<b>R44</b>	Down	<b>ZC40</b>	Up	<b>ZK41</b>	Up	
	16	<b>ZH34+</b>	Up	<b>ZF45</b>	Up	<b>ZC41</b>	Up	<b>ZN40</b>	Up	
	17	<b>ZQ54</b>	Down	<b>R45</b>	Down	<b>ZD40</b>	Up	<b>ZN41</b>	Up	
	18	<b>ZJ42</b>	Up	<b>045</b>	Up	<b>ZD41</b>	Up	<b>ZS40</b>	Up	
	19	<b>ZS42</b>	Down	<b>ZR43</b>	Down	<b>ZE40</b>	Up	<b>ZS41</b>	Up	
	20	<b>ZJ43</b>	Up	<b>UN44</b>	Up	<b>ZE41</b>	Up	<b>ZQ40</b>	Up	
	21	<b>ZS43</b>	Down	<b>ZR44</b>	Down	<b>ZF40</b>	Up	<b>ZQ41</b>	Up	
	22	<b>ZJ44</b>	Up	<b>UN45</b>	Up	<b>ZF41</b>	Up	<b>ZP40</b>	Up	
	23	<b>ZQ42</b>	Down	<b>ZA40</b>	Up	<b>040</b>	Up	<b>ZP41</b>	Up	
	24	<b>ZK42</b>	Up	<b>ZA41</b>	Up	<b>041</b>	Up	<b>ZR40</b>	Up	
	25			<b>ZB40</b>	Up	<b>H40</b>	Up	<b>ZR41</b>	Up	
26										
27										
28										
29										
30										
31										
TOP										

The spacer between positions number 1 and 2 contains Neutron Dosimeter Number     0

<b>POS. 2 JP-27</b>	M3-PCCVN specimen	Passive thermometry	
	1. outer <b>XE34</b>	1.  Ser. #1	2.  Ser. #2
	2. inner <b>XE35</b>		
	3. inner <b>XE36</b>		
	4. outer <b>XF34</b>		
	5. outer <b>XF35</b>		
	6. inner <b>XG34</b>		
	7. inner <b>XG35</b>		
8. outer <b>XG36</b>			
<b>POS. 3 JP-27</b>	M3-PCCVN specimen	Passive thermometry	
	1. outer <b>XF36</b>	1.  Ser. #3	2.  Ser. #4
	2. inner <b>534</b>		
	3. inner <b>535</b>		
	4. outer <b>634</b>		
	5. outer <b>635</b>		
	6. inner <b>XH34</b>		
	7. inner <b>536</b>		
8. outer <b>636</b>			

The spacer between positions number 3 and 4 contains Neutron Dosimeter Number     V    

<b>POS. 4 JP-27</b>	SS-J3 tensile specimen	APFIM specimen	Passive thermometry
	1. inner <b>531</b>	1. <b>53A</b>	1. Ser. #1
	2. outer <b>530</b>	2. <b>53B</b>	
	3. inner <b>532</b>	3. <b>53C</b>	2. Ser. #2
	4. outer <b>533</b>	4. <b>53D</b>	
	5. inner <b>031</b>	5. <b>03A</b>	3. Ser. #3
	6. outer <b>030</b>	6. <b>03B</b>	
	7. inner <b>032</b>	7. <b>03C</b>	4. Ser. #4
8. outer <b>033</b>	8. <b>03D</b>		
<b>Bottom half</b>	SS-J3 tensile specimen	APFIM specimen	Passive thermometry
	9. inner <b>631</b>	9. <b>63A</b>	5. Ser. #5
	10. outer <b>630</b>	10. <b>63B</b>	
	11. inner <b>632</b>	11. <b>63C</b>	6. Ser. #6
	12. outer <b>633</b>	12. <b>63D</b>	
	13. inner <b>H31</b>	13. <b>H38</b>	7. Ser. #7
	14. outer <b>H30</b>	14. <b>H39</b>	
	15. inner <b>H32</b>	15. <b>H3A</b>	8. Ser. #8
16. outer <b>H33</b>	16. <b>H3B</b>		

<b>POS. 5 JP-27</b>  <b>Top half</b>	SS-J3 tensile specimen	APFIM specimen	Passive thermometry
	1. inner <b>UA17</b>	1. <b>R44</b>	1. Ser. #9
	2. outer <b>UA16</b>	2. <b>R45</b>	
	3. inner <b>R40</b>	3. <b>340</b>	2. Ser. #10
	4. outer <b>R41</b>	4. <b>341</b>	
	5. inner <b>XE41</b>	5. <b>ZQ44</b>	3. Ser. #11
	6. outer <b>XE40</b>	6. <b>ZQ45</b>	
	7. inner <b>XE42</b>	7. <b>ZQ46</b>	4. Ser. #12
8. outer <b>XG40</b>	8. <b>ZQ47</b>		
<b>Bottom half</b>	SS-J3 tensile specimen	APFIM specimen	Passive thermometry
	9. inner <b>ZP41</b>	9. <b>ZP42</b>	5. Ser. #13
	10. outer <b>ZP40</b>	10. <b>ZP43</b>	
	11. inner <b>XQ40</b>	11. <b>ZQ42</b>	6. Ser. #14
	12. outer <b>ZQ41</b>	12. <b>ZQ43</b>	
	13. inner <b>XF41</b>	13. <b>ZQ48</b>	7. Ser. #15
	14. outer <b>XF40</b>	14. <b>ZQ49</b>	
	15. inner <b>XF42</b>	15. <b>ZQ4A</b>	8. Ser. #16
16. outer <b>XG41</b>	16. <b>ZQ4B</b>		
<b>POS. 6 JP-27</b>  <b>Top half</b>	SS-J3 tensile specimen	APFIM specimen	Passive thermometry
	1. inner <b>541</b>	1. <b>54B</b>	1. Ser. #17
	2. outer <b>540</b>	2. <b>54C</b>	
	3. inner <b>542</b>	3. <b>54D</b>	2. Ser. #18
	4. outer <b>543</b>	4. <b>54E</b>	
	5. inner <b>041</b>	5. <b>04A</b>	3. Ser. #19
	6. outer <b>040</b>	6. <b>04B</b>	
	7. inner <b>042</b>	7. <b>04C</b>	4. Ser. #20
8. outer <b>043</b>	8. <b>04D</b>		
<b>Bottom half</b>	SS-J3 tensile specimen	APFIM specimen	Passive thermometry
	9. inner <b>641</b>	9. <b>64B</b>	5. Ser. #21
	10. outer <b>640</b>	10. <b>64C</b>	
	11. inner <b>642</b>	11. <b>64D</b>	6. Ser. #22
	12. outer <b>643</b>	12. <b>64E</b>	
	13. inner <b>H41</b>	13. <b>H49</b>	7. Ser. #23
	14. outer <b>H40</b>	14. <b>H4A</b>	
	15. inner <b>H42</b>	15. <b>H4B</b>	8. Ser. #24
16. outer <b>H43</b>	16. <b>H4C</b>		



<b>POS. 9 JP-27</b>	Outer layer DFMB specimens (.065 x .065 x .362 in)												Inner layer DFMB (.0157x .130 x .362 in)		Inner layer DFMB (.035 x .130 x .362 in)		Passive therm.
	C	C	C	C	S	S	S	S	TB	TB	TB	TB	M2	M2	M1	M1	
<b>Row 1 TOP</b>	1	2	3	4	5	6	7	8	9	10	11	12	1	2	3	4	1.  Ser. #1
	<b>050a</b>	<b>050b</b>	<b>050c</b>	<b>050d</b>	<b>550a</b>	<b>550b</b>	<b>550c</b>	<b>550d</b>	<b>650a</b>	<b>650b</b>	<b>650c</b>	<b>650d</b>	<b>051</b>	<b>H50</b>	<b>R50</b>	<b>R51</b>	
<b>Row 2 BOTTOM</b>	<b>050e</b>	<b>050f</b>	<b>050g</b>	<b>050h</b>	<b>550e</b>	<b>550f</b>	<b>550g</b>	<b>550h</b>	<b>650e</b>	<b>650f</b>	<b>650g</b>	<b>650h</b>	<b>551</b>	<b>651</b>	<b>552</b>	<b>652</b>	

<b>POS. 10 JP-27</b>	Outer layer DFMB specimens (.065 x .065 x .362)												Inner layer DFMB (.0157x .130 x .362 in)		Inner layer DFMB (.035 x .130 x .362 in)		Passive therm.
	C	C	C	C	S	S	S	S	TB	TB	TB	TB	M2	M2	M1	M1	
<b>Row 1 TOP</b>	1	2	3	4	5	6	7	8	9	10	11	12	1	2	3	4	Ser. #2
	<b>048a</b>	<b>048b</b>	<b>048c</b>	<b>048d</b>	<b>548a</b>	<b>548b</b>	<b>548c</b>	<b>548d</b>	<b>648a</b>	<b>648b</b>	<b>648c</b>	<b>648d</b>	<b>049</b>	<b>H48</b>	<b>R42</b>	<b>R43</b>	
<b>Row 2 BOTTOM</b>	<b>048f</b>	<b>048f</b>	<b>048g</b>	<b>048h</b>	<b>548e</b>	<b>548f</b>	<b>548g</b>	<b>548h</b>	<b>648e</b>	<b>648f</b>	<b>648g</b>	<b>648h</b>	<b>549</b>	<b>649</b>	<b>54A</b>	<b>64A</b>	





